



# NG16 GAS METER



- Submetering Applications
- Compact size
- Indoor Use
- Aluminum Body
- NTEP California Approved

The NG16 diaphragm gas meter is made to measure accurately submetering applications of gas appliances. The aluminum construction along with the sealed register allows it to be installed in many applications where size is of utmost importance. The pulse output allows for integration of remote totalizers and communications devices.

### Technical Characteristics

Use.....Natural gas and LPG\*  
 Cyclic volume..... 0.0317ft<sup>3</sup>  
 Operating temperature .....14° F to 104° F  
 Storage temperature .....-4° F to +122° F

\* please contact us for any other type of gas.

Maximum Operating Pressure .....4.35 PSI  
 Measuring range .....Qmin 0.56 ft<sup>3</sup>/h Qmax 88 ft<sup>3</sup>/h  
 Pulse transmitter..... LF-system, 12 Vdc max  
 10 mA max, standard 1 ft<sup>3</sup>/pulse

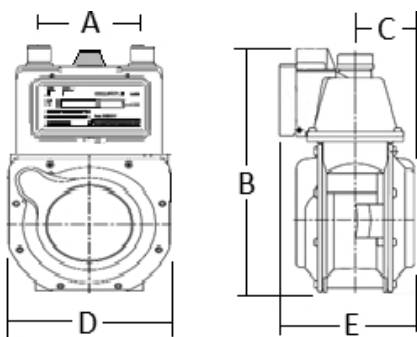

Meter Case Material	A in	B in	C in	D in	E in	Wt lb	Connection Threads
Aluminum	5.1	9	2.8	6.7	5.3	4.2	½" NPT

Typical accuracy curve

